

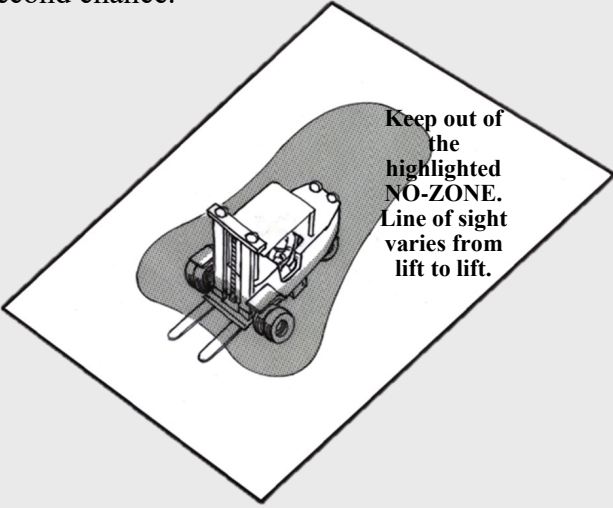

Forklift Safety

We work in an industrial environment with heavy equipment all around us. Forklifts are no exception. They are a necessary tool that operate in almost every area of our facility. You do not need to be a forklift operator to appreciate the hazards associated with working in and around forklifts.

Forklifts are safe when they are respected by their operators and those working around them. Forklifts have large blind spots, and you can never assume a forklift operator sees you. We need to provide ample room for forklifts to maneuver. It is true that pedestrians have the right of way, but we should never test our heavy equipment operators. We may not get a second chance.



Forklift operations are no different than any other task in that they require a pre-job briefing and an assessment of risk prior to commencing. We work in a dynamic environment and risks need to be continually assessed throughout the day. Some common risks that are experienced are operating in tight spaces, pinch points, propane burns, uneven driving surface, improperly secured loads, etc. All of these examples could lead to serious injuries and damaged material.

We have had 16 forklift accidents so far in 2023. This is high. Thankfully, the majority have been level three events that we can learn from. Each one is a reminder

that we need to perform as trained, not take shortcuts, and stop until all identified risks have been mitigated. One example is where we ask for a spotter when we cannot see around the load.

If a forklift accident occurs, we need to stop, secure, and notify a member of management. This allows for proper notification of the D950 team to assess the scene and capture the learning before altering the scene.

All of us need to work together in order to deliver the advantage that protects our sailors, our families, and our freedom.

Patrick Saggal
Senior Manager of Engineering

FOLLOW EB SOCIAL MEDIA CHANNELS

Facebook:
General Dynamics Electric Boat

Twitter:
@GDElectricBoat

Instagram:
gdelectricboat

YouTube:
GD Electric Boat

LinkedIn:
General Dynamics Electric Boat

EB Landing:
www.EBlanding.com

CONTINUOUS IMPROVEMENT

How to Identify Meaningful Improvement Opportunities

"None of us is as smart as all of us."

- Ken Blanchard, author of One Minute Manager

If you are asked for two ideas, do you find it tough to just come up with something that you can do that will actually be helpful at making your job tasks easier, safer, and smarter? We're going to share some best practices from other teams for figuring out how to ask for employee input so we can achieve two ideas per employee goal, while still adhering to our Core Values. The leadership team is committed to listening to your input, and recognizing you for your contributions towards improving your tasks in ways that help you and your coworkers.

1. Take credit for what you've already done. Walk as a group and take a look at what has changed in the past few months. Are any of the changes related to process improvements your team came up with and did?
2. Schedule a monthly brainstorming session using [this technique](#) to talk about recent challenges or upcoming opportunities. This takes a traditional hot wash and bumps it up a level.
3. Make it safe by finding low risk ways to see if the idea works well. Let your team know how they can test something on a trial basis or area so any outcome is ok, and the attempt is recognized as a success.
4. Set up an innovation or collaboration zone/time. This might be a monthly 'Shark Tank' employees can bring ideas to with reps from different support areas, a bulletin board with recent successful ideas, an innovation showcase fair with recent successes, or any other set-up that encourages employees to think about the way they have always done things, and look at it differently.
5. Ask the team what they want to learn about. Help them by working together to find ways to improve current processes while letting them explore what they are interested in.
6. Show the team how one good idea has sincerely produced real results and why.
7. Enable cross-silo collaboration by having front line employees from different organizations work together. Ask teams that come after you to see how your work affects them and what changes they wish you'd make so their work can go quicker. It might a quick change to a template or something bigger, but you'll never know if you don't ask.
8. Create out-of-the-box thinking opportunities. Read an article together, bring up a new concept, listen to a TED talk. Each person will interpret or be inspired differently based on their experiences and perspective.



Technique is found here: [\\us-ct-eb01\EBDepts\Eng.670\Continuous_Improvement_Public\Groton Ops Demo\Employee Engagement\Idea Generation\Brainstorming PICK.pptx](#)

D973 Training has a new trailer on the QP Waterfront – Trailer # 6. This trailer is gray and located in the alleyway in-between buildings 2004 & 2006 (west-side). Trailer 6 has replaced trailer 17 and will now show up in Cornerstone as a training location. See the map to the right for a visual reference.

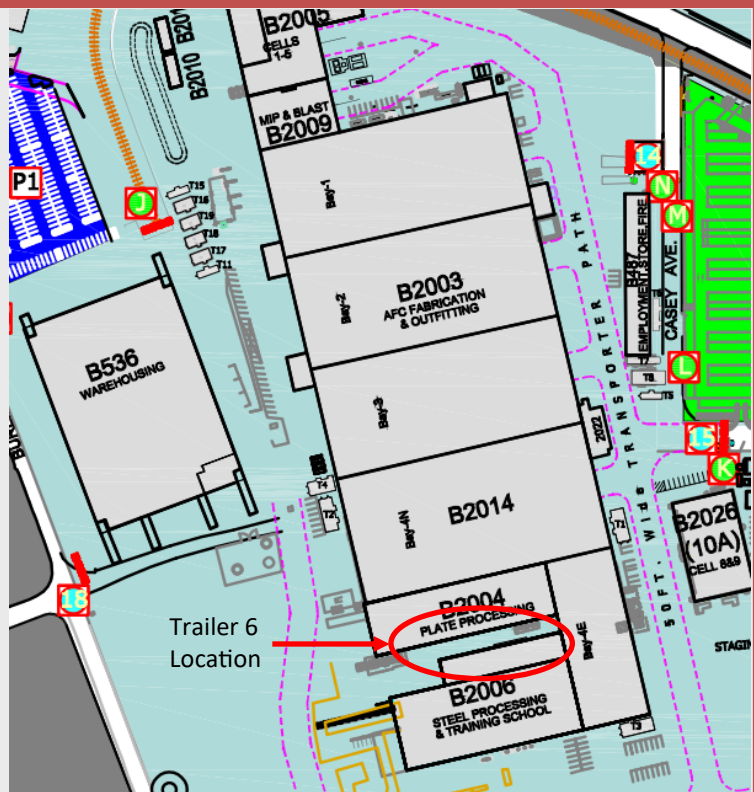

EBQP Breast Cancer Awareness Shirts

The Quonset Point FMO team is raising money as they do every year to support Breast Cancer Research. All proceeds from sales will support this effort. The current deadline for ordering is Tuesday, September 12th. This year, the online store includes short sleeve T-shirts, long sleeve T-shirts, Carhartt mid-weight hooded sweatshirts, heavy blend hooded sweatshirts, and full-zip hooded sweatshirts. To order yours, please visit

<https://ebbc2023.itemorder.com/>. Please note, there will be no shipping to Electric Boat, please use your home address or select pickup at Impact in Cumberland, RI. Support a great cause and order yours today!



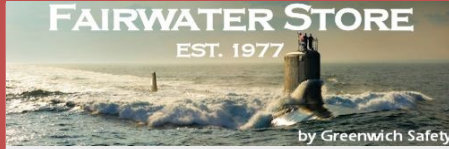

- **First Edition NEW SSN 778 USS NEW HAMPSHIRE COIN!! Add to your collection Today!!**
- **Just Arrived!! Seawolf Apparel!! Adult & Youth Sizes Available!!**
- **CATERPILAR Hat & Sock Bundle ONLY \$20.00 !!!**
- **See Fairwater.com for custom merchandise ordering!!**

Hours of Operation
7:30 am to 4:00 pm



QP Weekly Safety Briefing

09/03/2023 – 09/09/2023

200%
ACCOUNTABILITY

BACK TO WORK, BACK TO SAFETY

Emphasizing Safety Habits After Time Away From Work

Tuesday - 9/5/2023

First/Second Leadership Stand Downs for all Operations Employees

Week 37

GENERAL DYNAMICS
Electric Boat

EBP-02852: EB has established health and safety as the company's number one priority.

EB 1st Shift Bowling League



Team Meeting September 13th @ 3:45pm

Bowling Starts September 20th @ 4pm

Kingstown Bowl

6125 Post Rd.

North Kingstown, RI

Contact Dave Rull - 401-226-6442 (Bldg 9A)